



Reyrolle  
Protection  
Devices

## 7PG17 - XR

Intertipping, Interposing, Supervision and Special Purpose Relays.

Answers for energy

# 7PG17 – XR101 & XR102

Intertripping Relay



## Description

Type XR relays are developments for specific applications from the AR relay range. They are electro-mechanical relays with a consistent positive action, a long service life and complying with BS142.

XR101 – This relay is supplied with a loose 1500 ohm resistor for wiring in series with the coil. The resistor should be mounted vertically on a steel cubicle or switchgear compartment side sheet.

XR102 – This relay requires a 200 ohm resistor to be wired in series with the coil. As the resistor is a requirement of the overall intertripping scheme detailed by ESI 41-15 Part 5, it is NOT SUPPLIED with the relay.

## Application

Type XR101 and XR102 are intended for use as intertrip send and receive relays.

XR101 intertrip send complies with ESI 48-4 Class ES1

XR102 intertrip send complies with ESI 41-15 Part 5 (1988)

## Technical Data

	XR01	XR02
Rating	124Vd.c	48Vd.c
Operating time	10ms	15ms
Minimum operate current	25ms	10mA
Continuous maximum withstand at -40 C ambient	143V	60V
Maximum burden (Including external resistors)	13W	10W

Operating Range 50% to 120% of rated voltage

Thermal withstand

Both relays will withstand 13 times rated voltage for 10 seconds

Contact arrangement

XR101 – 2 normally open self reset

XR102 – 3 normally open and 1 normally closed self reset

## Contracting

Make and carry continuously

1250VAa.c. or 1250Wd.c. within the limits of 660V and 5A

Make and carry for 3 seconds

7500VAa.c. or 7500Wd.c. within the limits of 660V and 30A

Break:

1250VA a.c. or 100W (resistive) d.c. or 50W (inductive)L/R = 0.04 d.c. with limits of 250V and 5A

Indication

Both relays are fitted with hand reset flags

insulation

2kV 50Hz rms for 1 minute:

Between contacts to earth and to the coil

Between any case terminal and earth

Between case terminals of independent circuits

1kV 50Hz rms for 1 minute across normally open contacts

Temptation

In service: -10°C to 55°C

Storage: -25°C to 70°C

Mechanical durability

Vibration, relays comply with BS142 section 2.1 category S2

Shock, relays will withstand a 20G shock or impact on the panel without operating

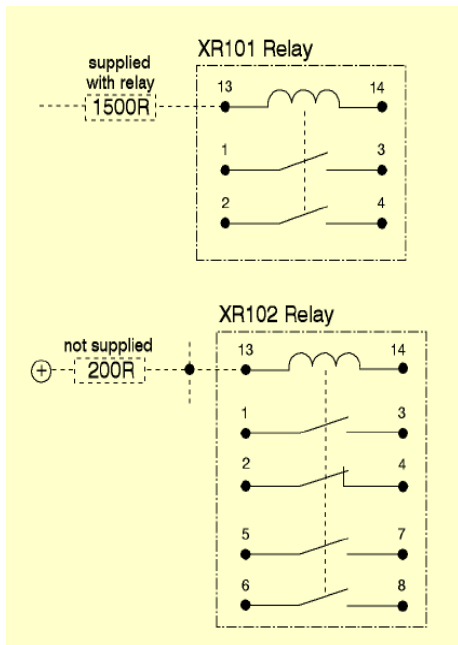

Fig 1. Connection details

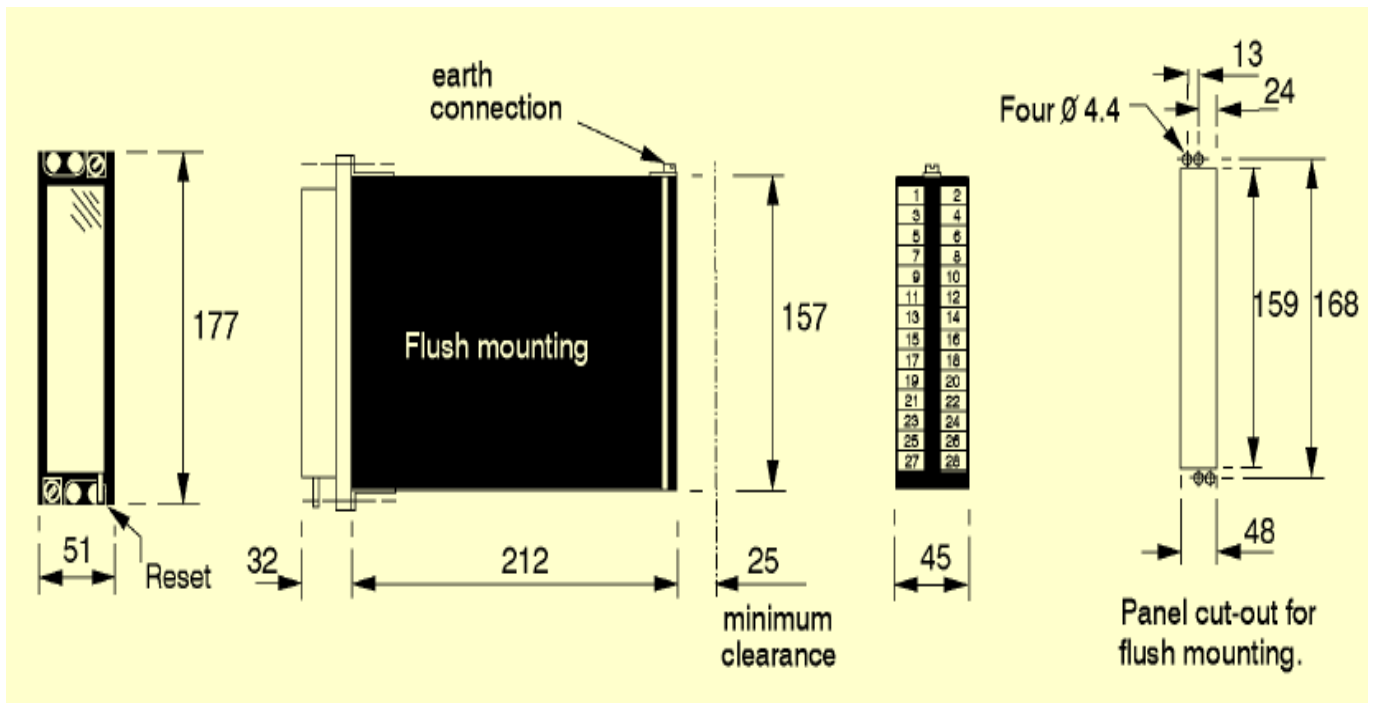

Fig 2. Dimensions of modular size 2 case (all dimensions are in mm)

# 7PG17 XR105 and XR106, XR205 and XR206

Interposing Relays



## Description

Type XR205 and XR206 are two element versions of the XR105 and XR106 respectively with the same performance. Type XR relays are developments for specific applications from the type AR relay range. They are electro-mechanical relays with a consistent positive action, a long service life and complying with BS142. Type XR105 has no flag indicator, type XR106 has a hand reset flag. Both types are available with a suppression diode across the coil to reduce the effects of the back emf which occurs on switch-off.

## Application

Types XR105 and XR106 are intended for the remote control of switchgear and associated equipment over pilot wires with a maximum resistance of 200 ohms. These relays are designed so that they are not susceptible to certain a.c. voltage levels which may be induced onto the pilots wires.

## Technical information

External resistor required for 125Vd.c. operation  
Operating range. With zero pilot resistance  
78 to 125% of nominal rated voltage

With a maximum pilot loop resistance of 200ohm 92 to 125% of nominal rated voltage.  
Burden Typically 3.7W for a relay with 4 normally open contacts.

### A.C. Rejection

For a 48Vd.c. rated relay, typically 110V 50Hz a.c.  
Operating time  
For a relay rated 48Vd.c. with 4 normally open contacts at rated voltage typically 30ms. With 200ohms pilot resistance less than 80ms. Reset time is less than 35ms

### Contacts

2 normally open, 4 normally open or 2 normally open and 2 normally closed self reset. Up to two contacts can have a heavy duty rating by fitting blow-out magnets  
Normal duty, contact ratings  
Make and carry continuously  
1250VAa.c. or 1250Wd.c. within the limits of 660V and 5A

Make and carry for 3 seconds  
7500VAa.c. or 7500Wd.c.  
within the limits of 660V and 30A

### Break:

1250VAa.c. or 100W (resistive) d.c. or 50W (inductive)  
L/R = 0.04, d.c. within the limits of 250V and 5A

### Heavy duty contact ratings

Make and carry continuously  
1250W d.c. within the limits of 660V and 5A  
Make and carry for 3 seconds  
7500Wd.c. within the limits of 660V and 30A  
Break, see duty curves over the page  
Indication XR106, hand reset flag  
Insulation

2kV 50Hz rms for 1 minute  
between contacts to earth and to the coil  
between any case terminal and earth  
between case terminals of independent circuits  
1kV 50Hz rms for 1 minute across normally open contacts

### Temperature

In service: -10°C to 55 °C  
Storage -25 °C to 70°C

### Mechanical durability

Vibration, relays comply with BS142, Section 2.1  
Category S2.

Shock, relays will withstand a 20G shock or impact on the panel without operating. Operational/mechanical life, relays will withstand in excess of 10,000 operations with the contact rating stated.

Epsilon case	Plug-in no. 13 case
1	S2A
2	S1A
3	S2B
4	S1A
5	
6	
7	
8	
13	DC
14	DC

Table 1. case terminal numbers

Normally closed contact location (Epsilon case terminal numbers)				
	1-3	2-4	5-7	6-8
1 NC		NC		
2 NC	NC	NC		
3 NC	NC	NC		NC
4 NC	NC	NC	NC	NC

Table 2. normally closed contact location

Contact arrangement	Epsilon case terminal numbers			
	1	2	3	4
2 NO HD		+ ve		+ ve
1 NO HD+	Heavy duty		Standard duty	
		+ ve		
	Standard duty		Heavy duty	
			+ ve	
	Normally open		+ ve	
		+ ve		
	+ ve		+ ve	

Table 3. polarity of heavy duty contacts

Heavy duty contacts are fitted with blowout magnets and are polarity conscious. In Table 3' +ve' indicates the terminal which must be connected to the supply positive.

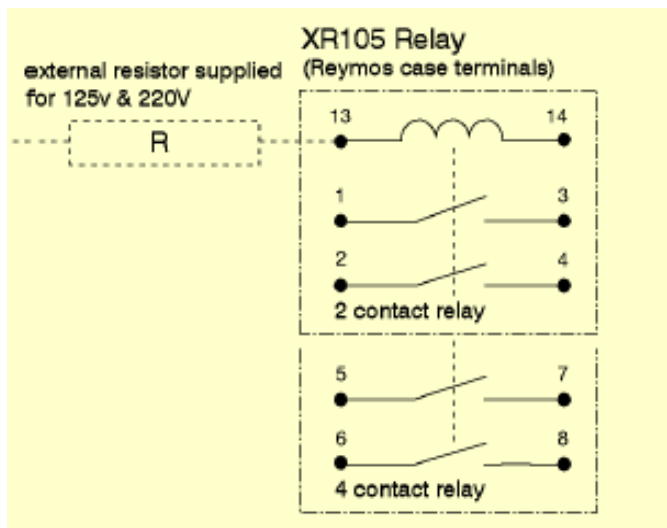

Fig 1. connection details for Epsilon Case

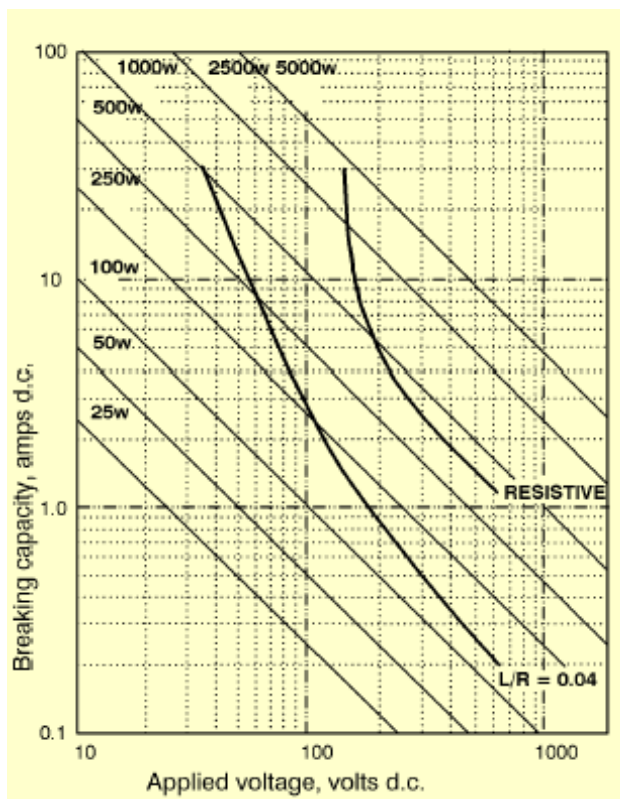

Fig 2. rating of heavy duty contacts

# 7PG17 XR151

Trip Relay Supervision Relay



## Description

Type XR relays are developments for specific applications of the type AR relay range. They are electro-mechanical relays with long service life and complying with the appropriate requirements of IEC 255 and BS 142. These relays have a low operating current, specific settings and time delayed drop-off. This latter feature is to keep the relay in the operated condition during temporary reductions in the battery voltage, such as those which occur just prior to a fuse blowing or during a busbar fault when many trip relays operate simultaneously.

## Application

Type XR151 relays are designed to allow the supervision of a trip relay operating coil, supply & associated wiring. This application requires relays with low operating current, visual indication and the ability to initiate a remote alarm. Both these relays have mechanical flag indicators which show on de-energisation, either self reset or hand reset.

Low burden & consistent, positive action  
Suitable for high burden trip relays (EB2) only.

Exact burden & operating current dependent upon application.

## Technical information

Rated voltage V n	125V
Settings	Pick-up: 70% of Vn Drop-off: not less than 26% of Vn
Reset time	No less than 100ms when supply is switched from 100% to 26% of Vn.
Operating current	Less than 20mA.
Burden	Less than 2.5W

Thermal Withstand	1.15 Vn continuously
Indication	A self or hand reset flag indicator shows when the relay is de-energised.

### Contact arrangements

4 contacts in any combination of normally open or normally closed

#### Contact rating

Make and carry continuously:  
1250VA a.c. or 1250Wd.c.  
with limits of 660V and 5A

#### Make and carry for 3 seconds:

7500VA a.c. or 7500Wd.c.  
with limits of 660V and 30A

#### Break

1250VA a.c. or 100Wd.c. resistive, or 50W  
inductive (L/R = 0.04) d.c. with limits of 250V

## Environmental Information

Temperature	IEC 68-2-1 & 2
-Storage -	25°C to +70°C
-Operating -	10°C to +55°C
Humidity	IEC 68-2-3
	56 days at 95% RH and 40°C
Vibration	IEC 255-21-1

The relays meet the requirements of Class 1 for vibration response and endurance

#### Shock and bump IEC 255-21-2

The relays meet the requirements of IEC 255-21-2 and BS142, sub-section 1.5.2. (1989) with respect to shock and bump testing for class 1 severity

#### Mechanical life

The relays will withstand in excess of 10,000 operations with the contact rating at a rate of 600 operations per hour

#### Insulation IEC 255-5

Relays will withstand:  
5kV peak, 1.2/50µs, 0.5J between all terminals and case earth and between adjacent terminals.  
2kV rms 50Hz for 1 minute between all case terminals connected together and the case earth and between independent circuits.  
1kV rms 50Hz for 1 minute between normally open contacts.

# 7PG17 XR152 and XR153

Supply Supervision Relays



## Description

Type XR relays are developments for specific applications of the type AR relay range. They are electro-mechanical relays with long service life and complying with the appropriate requirements of IEC 255 and BS 142. These relays have a low operating current, specific settings and time delayed drop-off. This latter feature is to keep the relay in the operated condition during temporary reductions in the battery voltage, such as those which occur just prior to a fuse blowing or during a busbar fault when many trip relays operate simultaneously. Healthy circuits therefore do not give spurious alarms and the relay effected by the fuse failure provides the alarm and indication necessary for accurate maintenance attention.

## Application

Types XR152 and XR153 relays are designed to comply with CEGB and other specification for protection supervision requirements and the monitoring of d.c. voltage supplies. These applications require relays with low operating current, visual indication and the ability to initiate a remote alarm. Both these relays have mechanical flag indicators which show on de-energisation, self reset on the XR152 and hand reset on the XR153.

Low burden

Versatile design, can provide pre-close supervision  
Consistent positive action

## Technical information

Rated voltage V <sub>n</sub>	24V, 30V, 50V, 60V, 125V and 220Vdc
Settings	Pick-up 70% of rated volt-

	age Drop-off not less than 26% of V <sub>n</sub>
Reset time	No less than 100ms when supply is switched from 100% to 26% of V <sub>n</sub> .

Operating current	10mA nominal. (17mA for 24V & 30V ratings)
Burden	0.4W at 24Vd.c. 1.25W at 125Vd.c
Thermal Withstand	1.15 V <sub>n</sub> continuously
Indication	A flag indicator shows when the relay is de-energised XR152 self reset flag XR153 hand reset flag

## Contact arrangements

2 or 4 contacts in any combination of normally open and normally closed

Contact rating

Make and carry continuously:  
1250VA a.c. or 1250Wd.c.  
with limits of 660V and 5A

Make and carry for 3 seconds:  
7500VA a.c. or 7500Wd.c  
with limits of 660V and 30A

Break

1250VA a.c. or 100Wd.c. resistive, or 50W inductive (L/R = 0.04) d.c. with limits of 250V

## Environmental Information

Temperature	IEC 68-2-1 & 2
-Storage -	25°C to +70°C
-Operating -	10°C to +55°C
Humidity	IEC 68-2-3
	56 days at 95% RH and 40°C
Vibration	IEC 255-21-1

The relays meet the requirements of Class 1 for vibration response and endurance

Shock and bump IEC 255-21-2

The relays meet the requirements of IEC 255-21-2 and BS142, sub-section 1.5.2.

(1989) with respect to shock and bump testing for class 1 severity

### Mechanical life

---

The relays will withstand in excess of 10,000 operations with the contact rating at a rate of 600 operations per hour

### Insulation IEC 255-5

---

Relays will withstand:

5kV peak, 1.2/50 $\mu$ s, 0.5J between all terminals and case earth and between adjacent terminals.

2kV rms 50Hz for 1 minute between all case terminals connected together and the case earth and between independent circuits.

1kV rms 50Hz for 1 minute between normally open contacts.



# 7PG17 – XR250 to XR351

## Trip Circuit Supervision Relays



### Description

Type XR relays are developments for specific applications of the type AR relay range. They are electro-mechanical relays with a consistent positive action, a long service life and complying with the appropriate requirements of IEC 255 and BS142. Models XR250/251 have two attracted armature elements, XR350/351 have three. These relays incorporate a time delay on de-energisation to keep the relay in an operated condition during temporary reductions in the battery voltage.

#### Low burden

Versatile design, can provide pre-close supervision  
Consistent positive action

Supervision of the trip circuit breaker is desirable as a means of ensuring the integrity to the trip circuit.

There are differing requirements for monitoring a trip circuit, supervision of the trip with the circuit breaker closed, supervision with the circuit breaker open and closed and pre-closing supervision. These XR relays are designed to meet all of these requirements and in particular the requirements of BEBS S15 schemes H4 and H7.

XR250 and XR251 Circuit breaker closed supervision will initiate an alarm and provide indication with the circuit closed for : Failure of the trip supply, open circuit trip coil, an open circuit in the trip circuit wiring and if the trip coil should fail to respond to a trip command.

#### XR350 and XR351

Continuous supervision with the circuit breaker in the open and closed positions and in compliance with the scheme requirements of BEBS S15 scheme H7. XR350 and XR351 relays also have a contact for pre-closing supervision, where a circuit breaker is prevented from being closed if trip relays have not been reset. BEBS S15 scheme H7 is applicable to trip circuit voltages of 125Vd.c. and 240Vd.c.

### Technical information

Rated voltage V n	30V, 50V, 125V & 220Vdc
Operating range	80% to 120% of Vn
Reset time	400ms when supply is switched from Vn to off

#### Burden

H7 scheme relay burdens are typically:

Rated voltage	Trip circuit condition		Alarm circuit
	C.B. open	C.B. closed	
50Vd.c	--	--	2W
125Vd.c	1W	2W	4W
240Vd.c	2W	4W	9W

Thermal Withstand 1.15Vn continuous

#### Indication

A flag indicator shows when the relay is de-energised

Self reset flag XR250 and XR350

Hand reset flag XR251 and XR351

#### Contact arrangements

Alarm output - 4 contacts in any combination of normally open and normally closed. Pre-closing supervision, XR350 & XR351, 1 normally open contact.

#### Contact rating

Make and carry continuously:

1250VAa.c. or 1250Wd.c. with limits of 660V and 5A

Make and carry for 3 seconds:

7500VAa.c. or 7500Wd.c with limits of 660V and 30A

Break:

1250VAa.c. or 7500Wd.c. resistive, or 50W

inductive (L/R = 0.04) d.c. with limits of 250V and 5A

## Environmental

Temperature	IEC 68-2-1 & 2
Storage	-25°C to +70°C
Operating	-10°C to +55°C
Humidity	IEC 68-2-3 56 days at 95% RH and 40°C
Vibration	IEC 255-21-1

The relays meet the requirements of Class 1 for vibration response and endurance

### Shock and bump

IEC 255-21-2

The relays meet the requirements of IEC 255-21-2 and BS142, sub-section 1.5.2. (1989) with respect to shock and bump testing for class 1 severity

### Operational/mechanical life

The relays will withstand in excess of 10,000 operations with the contact rating at a rate of 600 operations per hour  
Insulation IEC 255-5

Relays will withstand:

5kV peak, 1.2/50 $\mu$ s, 0.5J between all terminals and case earth and between adjacent terminals

2kV rms 50Hz for 1 minute between all case terminals connected together, the case earth and between independent circuits

1kV rms 50Hz for 1 minute between normally open contacts

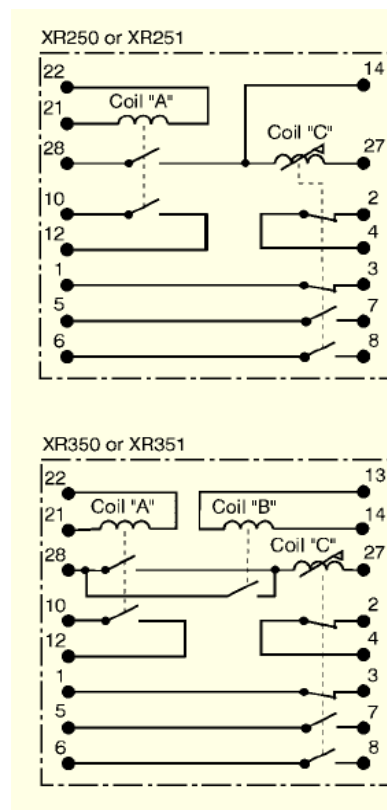

Fig 1. Typical relay wiring, modular case terminal numbers shown

# 7PG17 – XR309



## Description

This relay provides ferro-resonance detection as required by NGTS 3.15.2.

Three attracted armature elements are connected phase-to-phase via full wave rectifiers.

Under normal healthy conditions, with the system energised or de-energised, all the relay elements will be in unison and either operated or reset. No output is given.

## Application

On supergrid systems the phenomenon of ferro-resonance may be experienced following de-energisation of a directly connected transformer, and the ferro-resonance may be sustained by the induction from an energised parallel circuit. Re-energising the transformer whilst in a ferro-resonant state can risk severe switching overvoltages, therefore where there is such a risk, a ferro-resonance detector relay is essential.

## Operation

The relay will detect ferro-resonance, with the system energised or de-energised, as follows:

On system de-energisation, the secondary voltage falls below the reset level, and all 3 elements drop-off.

In the event of ferro-resonance occurring two out of three elements will remain energized

If ferro-resonance is induced onto a de-energisation system the relay will only respond if the amplitude of ferro-resonance is above the relay element pick-up level 40V a.c. Relay contacts initiate either an alarm timer or an external suppression circuit.

When a system is ferro-resonant, only two out of three elements remain energized, giving an output.

## Technical Information

Frequency	50Hz
Rating	110V a.c. Ø - Ø
Continuous rating	127V a.c.
Settings	Pick-up not greater than 40V a.c. 50Hz Drop-off not less than 25V a.c. 50Hz Relay operation is checked down to 16.67Hz

Burden	Approximately 3VA per element
Indication	None
Contacts	See Fig. 1

### Contact Rating

Make and carry continuously:  
1250VA a.c. or 100W (resistive) d.c. within the limits of 660V and 5A.  
Make and carry for 3 seconds:  
7500VA a.c. or 7500W d.c. within the limits of 660V and 5A.

### Insulation

2kV 50Hz rms for 1 minute:  
Between contacts to earth and to the coil  
Between any case terminal and earth  
Between case terminals of independent circuits.  
1kV 50Hz rms for 1 minute across normally open contacts.

### Temperature

Storage	-25°C to 70°C
In Service	-10°C to 40°C

### Mechanical Durability

Vibration  
Relays comply with IEC 255-21-1  
Shock  
Relays comply with IEC 255-21-2  
Seismic  
Relays comply with IEC 225-21-3  
Operational/mechanical life  
In excess of 10,000 operations with the contact rating stated.

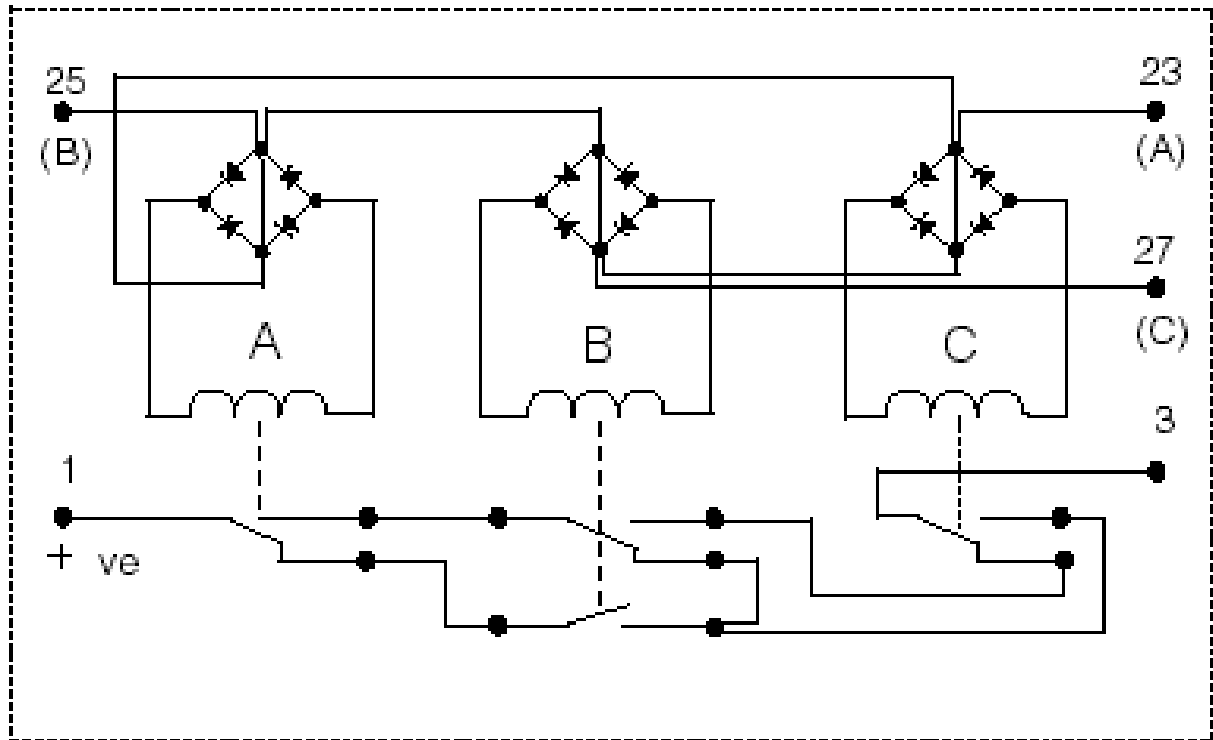

Fig 1. wiring diagram XR 309

# Ordering Information – 7PG17XR

Product description	Variants	Order No.
<b>Interposing control relay (XR105, XR106)</b>		<b>7 P G 1 7</b> □ □ - □ □ □ □ □ □ - □ □ □ □ <b>0</b>
		↑ ↑ ↑ ↑ ↑ ↑ ↑ ↑ ↑ ↑ ↑ ↑ ↑ ↑ ↑ ↑
<u>XR relay type</u> Interposing control		3
<u>Number of elements</u> Single element, self reset contacts		1
<u>Type of flag</u> No flag Hand reset flag		0 1
<u>Contact arrangement – NO</u> 0 NO 1 NO 2 NO 3 NO 4 NO		A B C D E
<u>Contact arrangement NC</u> 0 NC 1 NC 2 NC 3 NC 4 NC		A B C D E
<u>Number of contacts</u> <sup>3)</sup> Two Four		0 1
<u>Contact type</u> <sup>2)</sup> NO (Standard) / NC (Standard)		0
<u>Voltage rating</u> 24V DC 30V DC 50V DC 125V DC <sup>1)</sup>		1 2 3 4
<u>Housing size</u> Case size E2 (4U high)		A
<u>Voltage rating (alarm)</u> Not Applicable		A
<u>Back emf suppression diode</u> Not Fitted Fitted		0 1

1) Supplied with resistor VCE:2101H10152 (1500 Ohm) for wiring in series with the coil  
 2) Heavy duty contact arrangements available at extra cost. Please see separate non-MLFB list for already defined heavy duty contact arrangements. For arrangements not listed there please contact the factory.  
 3) Number of contacts must match selected contact arrangement

# Ordering Information – 7PG17XR

Product description	Variants	Order No.
Trip Relay supervision relay (XR151)		7 P G 1 7 □ □ - □ □ □ □ □ □ - □ □ □ 0
		↑ ↑ ↑ ↑ ↑ ↑ ↑ ↑ ↑ ↑ ↑ ↑ ↑ ↑ ↑ ↑
<u>XR relay type</u> Trip Relay supervision		5
<u>Number of elements</u> Single element, self reset contacts		1
<u>Type of flag</u> Hand reset flag Self reset flag		1 3
<u>Contact arrangement – NO</u> 0 NO 1 NO 2 NO 3 NO 4 NO		A B C D E
<u>Contact arrangement NC</u> 0 NC 1 NC 2 NC 3 NC 4 NC		A B C D E
<u>Number of contacts</u> Four		1
<u>Contact type</u> NO (Standard) / NC (Standard)		0
<u>Voltage rating</u> 125V DC		4
<u>Housing size</u> Case size E2 (4U high)		A
<u>Voltage rating (alarm)</u> Not Applicable		A
<u>Back emf suppression diode</u> Not Fitted		0

# Ordering Information – 7PG17XR

Product description	Variants	Order No.
D.C. supply supervision relay (XR152, XR153)		7 P G 1 7 □ □ - □ □ □ □ □ □ - □ □ □ □ 0
		↑ ↑ ↑ ↑ ↑ ↑ ↑ ↑ ↑ ↑ ↑ ↑ ↑ ↑ ↑ ↑
<u>XR relay type</u> D.C. supply supervision		4
<u>Number of elements</u> Single element, self reset contacts		1
<u>Type of flag</u> Hand reset flag Self reset flag		1 3
<u>Contact arrangement – NO</u> 0 NO 1 NO 2 NO 3 NO 4 NO		A B C D E
<u>Contact arrangement NC</u> 0 NC 1 NC 2 NC 3 NC 4 NC		A B C D E
<u>Number of contacts</u> Four		1
<u>Contact type</u> NO (Standard) / NC (Standard)		0
<u>Voltage rating</u> 24V DC 30V DC 50V DC 125V DC 240V DC		1 2 3 4 5
<u>Housing size</u> Case size E2 (4U high)		A
<u>Voltage rating (alarm)</u> Not Applicable		A
<u>Back emf suppression diode</u> Not Fitted		0

# Ordering Information – 7PG17XR

Product description	Variants	Order No.
<b>Interposing control relay (XR205, XR206)</b>		<b>7 P G 1 7</b> □ □ - □ □ □ □ □ □ - □ □ □ □ □
		↑ ↑ ↑ ↑ ↑ ↑ ↑ ↑ ↑ ↑ ↑ ↑ ↑ ↑ ↑
<u>XR relay type</u> Interposing control		3
<u>Number of elements</u> Two element, self reset contacts		2
<u>Type of flag</u> No flag Hand reset flag		0 1
<u>Contact arrangement – NO</u> 0 NO 1 NO 2 NO 3 NO 4 NO		A B C D E
<u>Contact arrangement NC</u> 0 NC 1 NC 2 NC 3 NC 4 NC		A B C D E
<u>Number of contacts/element</u> <sup>3)</sup> Two Four		0 1
<u>Contact type</u> <sup>2)</sup> NO (Standard) / NC (Standard)		0
<u>Voltage rating</u> 24V DC 30V DC 50V DC 125V DC <sup>1)</sup>		1 2 3 4
<u>Housing size</u> Case size E2 (4U high) Case size E4 (4U high)		A C
<u>Voltage rating (alarm)</u> Not Applicable		A
<u>Back emf suppression diode</u> Not Fitted Fitted		0

1) Supplied with resistor VCE:2101H10152 (1500 Ohm) for wiring in series with the coil  
 2) Heavy duty contact arrangements available at extra cost. Please see separate non-MLFB list for already defined heavy duty contact arrangements. For arrangements not listed there please contact the factory.  
 3) Number of contacts must match selected contact arrangement



# Ordering Information – 7PG17XR

Product description	Variants	Order No.
<b>Trip circuit supervision relay (XR250, XR251)</b>		<b>7 P G 1 7</b> □ □ - □ □ □ □ □ □ - □ □ □ □ □
		↑ ↑ ↑ ↑ ↑ ↑ ↑ ↑ ↑ ↑ ↑ ↑ ↑ ↑ ↑ ↑
<u>XR relay type</u> Trip circuit supervision		5 2
<u>Number of elements</u> Two element, self reset contacts		1 3
<u>Type of flag</u> Hand reset flag Self reset flag		A B C D E
<u>Contact arrangement – NO</u> 0 NO 1 NO 2 NO 3 NO 4 NO		A B C D E
<u>Contact arrangement NC</u> 0 NC 1 NC 2 NC 3 NC 4 NC		A B C D E
<u>Number of contacts/element</u> Four		1 0
<u>Contact type</u> NO (Standard) / NC (Standard)		0
<u>Voltage rating</u> 30V DC 50V DC 125V DC <sup>1)</sup> 240V DC <sup>1)</sup>		2 3 4 5
<u>Housing size</u> Case size E3 (4U high)		B
<u>Voltage rating (alarm)</u> 30V DC <sup>1)</sup> 50V DC <sup>1)</sup> 125V DC <sup>1)</sup> 240V DC <sup>1)</sup>		C D E F
<u>Back emf suppression diode</u> Not Fitted		0

<sup>1)</sup> Supplied with external resistors

# Ordering Information 7PG17XR

Product description	Variants	Order No.
<b>Trip circuit supervision relay (XR350, XR351)</b>		<b>7 P G 1 7</b> □ □ - □ □ □ □ □ □ - □ □ □ □
		↑ ↑ ↑ ↑ ↑ ↑ ↑ ↑ ↑ ↑ ↑ ↑
<u>XR relay type</u> Trip circuit supervision		5 3
<u>Number of elements</u> Three element, self reset contacts		1 3
<u>Type of flag</u> Hand reset flag Self reset flag		A B C D E
<u>Contact arrangement – NO</u> 0 NO 1 NO 2 NO 3 NO 4 NO		A B C D E
<u>Contact arrangement NC</u> 0 NC 1 NC 2 NC 3 NC 4 NC		A B C D E
<u>Number of contacts/element</u> Four		1
<u>Contact type</u> NO (Standard) / NC (Standard)		0
<u>Voltage rating <sup>2)</sup></u> 30V DC 50V DC 125V DC <sup>1)</sup> 240V DC <sup>1)</sup>		2 3 4 5
<u>Housing size</u> Case size E3 (4U high)		B
<u>Voltage rating (alarm)</u> 30V DC <sup>1)</sup> 50V DC <sup>1)</sup> 125V DC <sup>1)</sup> 240V DC <sup>1)</sup>		C D E F
<u>Back emf suppression diode</u> Not Fitted		0

1) Supplied with external resistors  
2) Voltage rating for both trip coils

# Ordering Information 7PG17XR

Product description	Variants	Order No.
<b>Ferro-resonance detector relay (XR309)</b>		<b>7 P G 1 7</b> □ □ - □ □ □ □ □ - □ □ □ □
		↑ ↑ ↑ ↑ ↑ ↑ ↑ ↑ ↑ ↑ ↑ ↑
<u>XR relay type</u> Ferro-resonance detector		6 3
<u>Number of elements</u> Three element, self reset contacts		0
<u>Type of flag</u> No flag		B
<u>Contact arrangement – NO</u> 1 NO		A
<u>Contact arrangement NC</u> 0 NC <sup>1)</sup>		0
<u>Number of contacts/element</u> Two		0
<u>Contact type</u> NO (Standard) / NC (Standard)		0
<u>Voltage rating</u> 110V AC		4
<u>Housing size</u> Case size E4 (4U high)		C
<u>Voltage rating (alarm)</u> Not Applicable		A
<u>Back emf suppression diode</u> Not Fitted		0

1) Contact arrangement 1 NO / 1 C/O per element



Published by and copyright © 2010:  
Siemens AG  
Energy Sector  
Freyeslebenstrasse 1  
91058 Erlangen, Germany

Siemens Protection Devices Limited  
P.O. Box 8  
North Farm Road  
Hebburn  
Tyne & Wear  
NE31 1TZ  
United Kingdom  
Phone: +44 (0)191 401 7901  
Fax: +44 (0)191 401 5575  
[www.siemens.com/energy](http://www.siemens.com/energy)

For more information, please contact our  
Customer Support Center.  
Phone: +49 180/524 70 00  
Fax: +49 180/524 24 71 (Charges depending on provider)  
E-mail: [support.energy@siemens.com](mailto:support.energy@siemens.com)

Power Distribution Division Order No. E53000-K7076-C48-2  
Printed in Fürth

Printed on elementary chlorine-free bleached paper.

All rights reserved.

Trademarks mentioned in this document are the property of Siemens AG, its affiliates, or their respective owners.

Subject to change without prior notice.

The information in this document contains general descriptions of the technical options available, which may not apply in all cases. The required technical options should therefore be specified in the contract.